

VME Bus 64ch·16bit A/D Conversion Board Advme2618



Preliminary

■ Features ■

- Input range - Selectable from 0~10V, 0~5V, 0~2.5V, 0~1.25V, ±10V, ±5V, ±2.5V, and ±1.25V
- Input channel - Front panel side : Single-end 64ch, differential 64ch
VMEbus-P2 side : Single-end 32ch, differential 16ch
- Input channels are not isolated each other, but analog circuit and digital circuit are isolated by photocoupler. Withstanding voltage is AC500V.
- Data acquisition - ① Continuous mode: acquires continuously until software stops
② Block mode: acquires specified channel only specified number of times
- Acquired data is stored in DPRAM(64KW) (1MB external memory is connected to FPGA)
- A/D conversion speed - Single channel scan : 200K sample/sec.
Multiple channel scan : 100K sample/sec.
- Trigger input - Selectable from the followings:
① External trigger from a dedicated connector on the front panel (TTL level, negative-going edge) ② Software trigger ③ Timer trigger
- RoHS - Compliant



■ Block Diagram ■

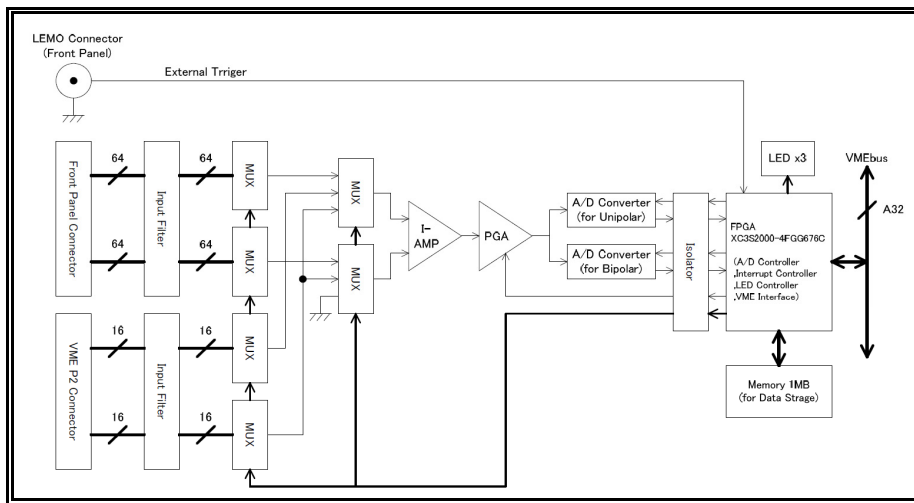

■ Specifications ■

Analog input	Channels	64ch (single-end/differential: front panel connector) 32ch (single-end: P2 connector) 16ch (differential: P2 connector)
	Input range	0~10V, 0~5V, 0~2.5V, 0~1.25V, ±10V, ±5V, ±2.5V, ±1.25V
	Input impedance	1MΩ (Typ)
	Input filter	100kHz (-3dB)
	Input connector	Front panel side: DIN96 pin x 2 VMEbus-P2 side: DIN96 pin
A/D converter	Resolution	16bit
	Output code	Unipolar input: binary Bipolar input: two's complement
	Integral linearity	±3LSB
	Differential linearity	±1LSB
	General accuracy	0.05% (F.S. at 25°C)
	Conversion cycle	Single channel scan : 200K sample/sec. Multiple channel scan : 100K sample/sec.
Isolation	Isolation type	Photocoupler (between analog circuit and digital circuit)
	Dielectric strength voltage	Input - system: AC500V (1 min.) Input - channel: non-isolated
Bus specification	Bus standard	Compliant with VME bus Revision.C.3
	Data width	16bit·8bit [D16, D8 (EO)]
	Address width	32bit [A32]·24bit [A24] Accessible at AM code 09H, 0DH, 39H, and 3DH
	Address occupied area	Occupies 256kB in VME A32 address space 0000000H~FFFFFFFH
	Interrupt function	Use one of the VME interrupt request lines *IRQ1~*IRQ7 Cause of interrupt is the end of A/D conversion
Others	Data acquisition memory	64KW
	External memory	1MB
	LED	Ready, Fail, TRIG
Supply voltage	Input supply voltage	DC5V:±5% (power feed from VME bus)
Form factor	VME double height, single width 172 x 262 x 20 mm (excl. projection portions)	

Note: Specifications are subject to change without prior notice.



www.advanet.co.jp email: sales@advanet.co.jp

Headquarters 616-4, Tanaka, Okayama 700-0951 JAPAN

Tokyo Branch KDX Kaji-cho 4F, 3-5-2 Kanda Kaji-Cho, Chiyoda-ku, Tokyo 101-0045 JAPAN



TEL +81-86-245-2861 FAX +81-86-245-2860

TEL +81-3-5294-1731 FAX +81-3-5294-1734